

# Novel *GREM1* Variations in Sub-Saharan African Patients With Cleft Lip and/or Cleft Palate

The Cleft Palate-Craniofacial Journal  
2018, Vol. 55(5) 736-742  
© The Author(s) 2018  
Reprints and permission:  
sagepub.com/journalsPermissions.nav  
DOI: 10.1177/1055665618754948  
journals.sagepub.com/home/cpc



Lord Jephthah Joojo Gowans, BSc, PhD<sup>1</sup>, Ganiyu Oseni, MBBS, FMCS<sup>2</sup>, Peter A. Mossey, BDS, PhD<sup>3</sup>, Wasiu Lanre Adeyemo, BDS, PhD, FMCS<sup>4</sup>, Mekonen A. Eshete, MD, FCS-ECSA<sup>5</sup>, Tamara D. Busch, BS, MSc<sup>6</sup>, Peter Donkor, MDSc<sup>1</sup>, Solomon Obiri-Yeboah, DMD<sup>1</sup>, Gyikua Plange-Rhule, MBChB<sup>1</sup>, Alexander A. Oti, BDS, FGCS<sup>1</sup>, Arwa Owais, BDS, MSc<sup>7</sup>, Peter B. Olaitan, MBBS, FMCS<sup>2</sup>, Babatunde S. Aregbesola, BDS, FCMS<sup>8</sup>, Fadekemi O. Oginni, BDS, FMCS<sup>8</sup>, Seidu A. Bello, BDS, FMCS<sup>9</sup>, Rosemary Audu, PhD<sup>10</sup>, Chika Onwuamah, PhD<sup>10</sup>, Pius Agbenorku, MD, PhD<sup>1</sup>, Mobolanle O. Ogunlewe, BDS, FWACS<sup>4</sup>, Lukman O. Abdur-Rahman<sup>11</sup>, Mary L. Marazita, PhD<sup>12,13</sup>, A. A. Adeyemo, MD<sup>14</sup>, Jeffrey C. Murray, MD<sup>6</sup>, and Azeez Butali, DDS, PhD<sup>15</sup>

## Abstract

**Objective:** Cleft lip and/or cleft palate (CL/P) are congenital anomalies of the face and have multifactorial etiology, with both environmental and genetic risk factors playing crucial roles. Though at least 40 loci have attained genomewide significant association with nonsyndromic CL/P, these loci largely reside in noncoding regions of the human genome, and subsequent resequencing studies of neighboring candidate genes have revealed only a limited number of etiologic coding variants. The present study was conducted to identify etiologic coding variants in *GREM1*, a locus that has been shown to be largely associated with cleft of both lip and soft palate.

**Patients and Method:** We resequenced DNA from 397 sub-Saharan Africans with CL/P and 192 controls using Sanger sequencing. Following analyses of the sequence data, we observed 2 novel coding variants in *GREM1*. These variants were not found in the 192 African controls and have never been previously reported in any public genetic variant database that includes more than 5000 combined African and African American controls or from the CL/P literature.

<sup>1</sup> Cleft Clinic, Komfo Anokye Teaching Hospital and Kwame Nkrumah University of Science and Technology, Kumasi, Ghana

<sup>2</sup> Department of Plastic Surgery, Ladoke Akintola University of Science and Technology, Osogbo, Nigeria

<sup>3</sup> Department of Orthodontics, University of Dundee, Dundee, United Kingdom

<sup>4</sup> Department of Oral and Maxillofacial Surgery, University of Lagos, Lagos, Nigeria

<sup>5</sup> Addis Ababa University, School of Public Health, Addis Ababa, Ethiopia

<sup>6</sup> Department of Pediatrics, University of Iowa, Iowa City, IA, USA

<sup>7</sup> Department of Pediatric Dentistry, University of Iowa, Iowa City, IA, USA

<sup>8</sup> Department of Oral and Maxillofacial Surgery, Obafemi Awolowo University, Ile-Ife, Nigeria

<sup>9</sup> State House Clinic, Abuja, Nigeria

<sup>10</sup> Department of Virology, Nigerian Institute of Medical Research, Lagos, Nigeria

<sup>11</sup> Division of Pediatric Surgery, Department of Surgery, University of Ilorin, Ilorin, Nigeria

<sup>12</sup> Center for Craniofacial and Dental Genetics, Department of Oral Biology, University of Pittsburgh, Pittsburgh, PA, USA

<sup>13</sup> Department of Human Genetics, University of Pittsburgh, Pittsburgh, PA, USA

<sup>14</sup> National Human Genome Research Institute, Bethesda, MD, USA

<sup>15</sup> Department of Oral Pathology, Radiology and Medicine, University of Iowa, Iowa City, IA, USA

## Corresponding Author:

Azeez Butali, DDS, PhD, Department of Oral Pathology, Radiology and Medicine/Dows Institute for Dental Research, College of Dentistry, University of Iowa, Butali Laboratory, ML2198, 500 Newton Road, Iowa City, IA 52242, USA.

Email: azeez-butali@uiowa.edu

**Results:** The novel variants include p.Pro164Ser in an individual with soft palate cleft only and p.Gly61Asp in an individual with bilateral cleft lip and palate. The proband with the p.Gly61Asp *GREM1* variant is a van der Woude (VWS) case who also has an etiologic variant in *IRF6* gene.

**Conclusion:** Our study demonstrated that there is low number of etiologic coding variants in *GREM1*, confirming earlier suggestions that variants in regulatory elements may largely account for the association between this locus and CL/P.

## Keywords

*GREM1* gene, cleft lip and/or cleft palate, soft palate cleft, sub-Saharan Africans, DNA sequencing

## Introduction

Cleft lip and/or cleft palate (CL/P) are congenital malformations of the face and palate present at birth and have a global incidence of 1 per 700 live births, though the incidence varies among Asians, Europeans, and Africans (Mossey and Modell, 2012). Syndromic forms of CL/P present with additional congenital abnormalities, whereas the more common nonsyndromic CL/P occur as isolated conditions (Dixon et al., 2011). Based on epidemiologic and embryologic evidences, nonsyndromic CL/P are classified as nonsyndromic cleft palate only (CP) and nonsyndromic cleft lip with or without cleft palate (CL±P) (Mossey and Modell, 2012). The nonsyndromic CL±P subphenotype may present as nonsyndromic cleft lip (CL) or nonsyndromic cleft lip and palate (CLP), whereas nonsyndromic CP may present as complete CP (cleft of both hard and soft palate) or incomplete CP (cleft of only the soft palate) (Dixon et al., 2011). Nonsyndromic CL±P comprises 70% of all CL±P cases, whereas nonsyndromic CP make up about 50% of all CP cases (Mossey and Modell, 2012; Leslie, Liu, et al., 2016).

The genetic etiology of nonsyndromic CL/P is complex in that they largely do not follow a clear Mendelian inheritance pattern. At least 40 loci have been reported at genome-wide significance levels in various studies on the etiology of nonsyndromic CL/P, with most studies conducted in populations of Asian and Caucasian ancestries. These loci were identified through large-scale linkage analyses, genome-wide association studies (GWAS), GWAS meta-analyses, as well as imputation, large-scale replication studies of GWAS-hit loci and resequencing of risk loci (Beaty et al., 2016; Leslie, Liu, et al., 2016; Leslie, Carlson, et al., 2016; Ludwig et al., 2016; Leslie et al., 2017; Ludwig et al., 2017; Yu et al., 2017). Various replication and DNA resequencing studies involving sub-Saharan Africans have suggested that some of these loci may be associated with nonsyndromic CL/P etiology in these populations (Butali et al., 2011; Butali et al., 2014a; Butali et al., 2014b; Gowans et al., 2016).

Gremlin 1 (*GREM1*; OMIM: 603054) was initially suggested to be the probable CL/P susceptibility gene at 15q13 when this locus attained a suggestive genome-wide significance in a nonsyndromic CL±P GWAS involving Europeans (Mangold et al., 2010). Direct DNA sequencing of *GREM1* and *noggin* (*NOG*), both of which are known antagonists of bone

morphogenetic protein 4 (*BMP4*), in Central Europeans demonstrated through burden analysis that some rare variants in *GREM1* were significantly associated with nonsyndromic CL±P in some of the applied tests, though these rare variants exhibited incomplete penetrance and no single causal variant was identified in cases (Al Chawa et al., 2014). In a study involving a Polish population, significant association was observed between nonsyndromic CL±P and common variants in *GREM1*, with one of the associated common variants having putative enhancer activity. Moreover, not a single etiologic rare variant was observed in cases that were sequenced (Mostowska et al., 2015). A 5.3-Mb deletion that encompasses *GREM1* has been reported in a girl with cleft palate, heart defects, and developmental delay (Erdogan et al., 2007), suggesting *GREM1* etiologic variants may result in syndromic CL/P. Noncoding variants near *GREM1* at the 15q13 locus have also been shown to contribute to variation in normal facial morphology, largely nose width, in Germans (Boehringer et al., 2011). Recently, a meta-analysis demonstrated a genome-wide significance association of noncoding variants near *GREM1* with nonsyndromic CLP, particularly cleft of both lip and soft palate but not the hard palate. Murine embryogenesis studies also showed that *GREM1* was expressed in the developing lip and soft palate but not the hard palate (Ludwig et al., 2016). In an earlier association study by our group (Gowans et al., 2016), a noncoding variant near *GREM1* demonstrated a trend toward nominal association with nonsyndromic CLP among our sub-Saharan African cohorts. As a BMP-antagonist that downregulates *BMP4* signaling in a dose-dependent manner, *GREM1* is also essential for early limb outgrowth and patterning because of its role in maintaining the FGF4-SHH feedback loop (Topol et al., 2000). A duplication encompassing the 3' untranslated region (UTR) of the *SCG5* gene and a region upstream of the *GREM1* locus causes allele-specific *GREM1* expression, culminating in reduced BMP pathway activity (Jaeger et al., 2012). Causative variants in *BMP4*, a gene that interacts with *GREM1*, have been observed in both overt and covert phenotypes of CL (Suzuki et al., 2009).

To date, no causative single-nucleotide variant (SNV) has been reported in the coding region of *GREM1* in patients with CL/P. However, a study (Mostowska et al., 2015) has suggested that alteration of expression levels of *GREM1* due to variants within an enhancer element that control *GREM1* may

**Table 1.** Samples From Individuals Who Went Through Direct DNA Sequencing.

Samples	Ghana, n	Ethiopia, n	Nigeria, n	Total, n
<b>Nonsyndromic</b>				
CL	32	33	33	98
CLP	40	46	38	124
CP	83	25	38	146
Total	155	104	109	368
Controls	96 <sup>a</sup>	96 <sup>b</sup>	2 <sup>c</sup>	
<b>Syndromic</b>				
CL	0	0	2	2
CLP	0	1	2	3
CP	18	1	5	24
Total	18	2	9	29

Abbreviations: CL, cleft lip; CLP, cleft lip and palate; CP, cleft palate only.

<sup>a</sup>Samples were sequenced using the primer set that covers the genomic region where a novel variant in *GREM1* was observed in a Ghanaian family.

<sup>b</sup>Samples were sequenced using the primer set that covers the genomic region where a novel variant in *GREM1* was observed in an Ethiopian family.

<sup>c</sup>These were Yoruba (Nigerian) samples from Centre d'Etude du Polymorphisme Humain (CEPH).

account for this gene's association with nonsyndromic CL ± P. The aim of the present study was to seek evidence of potentially pathogenic coding variants in *GREM1*. In the present study, we directly sequenced the coding exon of *GREM1* in CL/P patients from sub-Saharan Africa. We included both syndromic and nonsyndromic CL/P cases because variants linked to *GREM1* have been associated with both syndromic and nonsyndromic CL/P (Erdogan et al., 2007; Mostowska et al., 2015; Ludwig et al., 2016).

## Methods

### Subjects

All research protocols were approved by the local institutional review boards (IRBs) in the various participating countries. These include College of Health Sciences, Kwame Nkrumah University of Science and Technology (KNUST), Ghana—CHRPE/AP/217/13; College of Health Sciences, Addis Ababa University, Ethiopia—3.10/027/2015; and College of Medicine, University of Lagos, Nigeria—ADM/DCST/HREC/APP/1374.

To adhere to ethical standards, we obtained written informed consent from all participating families before samples were collected from them. Probands who were at least 18 years old signed their own informed consent whereas for those below 18 years, informed consent was signed by a parent or guardian.

We included 368 patients with nonsyndromic CL/P from Ghana, Ethiopia, and Nigeria (Table 1). The subphenotypes for this cohort comprised 98 nonsyndromic CL, 124 nonsyndromic CLP, and 146 nonsyndromic CP. A total of 29 patients who had syndromic CL/P were also recruited; this included 2 patients with syndromic CL, 3 patients with syndromic CLP, and 24 patients with syndromic CP.

### In Vitro Analyses of Saliva and Cheek Swab Samples

We used the Oragene DNA collection kits (<http://www.dnagenotek.com>) to collect saliva and cheek swab samples from participants. Detailed protocols on DNA processing, PCR, and gel electrophoresis are available at the Murray and Butali laboratories website (<http://genetics.uiowa.edu/protocols.php>). However, brief descriptions of these protocols are given here. We employed the optimized Oragene Saliva processing protocol to extract DNA from both saliva and cheek swab samples. After this, we determined the concentration of double-stranded DNA in each DNA sample using Quibit Assay that employed Quibit 2.0 Fluorometer (<http://www.invitrogen.com/site/us/en/home/brands/Product-Brand/Quibit.html>). As a quality control check, we conducted XY-genotyping of each sample employing the Taqman Assay kits and real-time PCR so as to validate the sexes of the samples.

We designed 2 primer sets to cover the only one coding exon as well as parts of the 5' and 3' untranslated regions (UTRs) of the *GREM1* gene. These primer sets were designed with Primer3 software ([http://biotools.umassmed.edu/bioapps/primer3\\_www.cgi](http://biotools.umassmed.edu/bioapps/primer3_www.cgi)) and we used the In Silico PCR tool in the UCSC genome browser (<https://genome.ucsc.edu/>) to ascertain whether these primer sets annealed to the targeted genomic region. Primer sets were designed based on *GREM1* Ref Seq number NM\_013372.6 of genome assembly number GRCh37/hg19, 2009 (<http://genome.ucsc.edu>). To determine the optimum PCR parameters for these primer sets, we conducted gradient PCR that varied the temperature and concentration of dimethyl sulfoxide (DMSO) on a PCR plate. Prior to DNA sequencing, we amplified the coding exon of *GREM1* using initial PCR. During this procedure, 9 μL of master mix (comprising 10× NH<sub>4</sub> buffer, 5% DMSO, 200 μM dNTPs, 50 μM MgCl<sub>2</sub>, water, 20 μM of forward and reverse primers as well as 5 U/μL Taq polymerase) was added to 1 μL of each DNA sample at a concentration of 4 ng/μL. Apart from the case samples on each 96-well PCR plate, 2 CEPH Yoruba (Centre d'Etude du Polymorphisme Humain) and 2 water samples were added to each plates to serve as template and nontemplate controls, respectively. The PCR conditions and primer sequences are available on request.

We confirmed the success of the initial PCR run by running part of the PCR product on 2% agarose gel and size markers at 100A and 220 V for 20 minutes. Gel electrophoretic products were viewed using ultraviolet light. Initial PCR products that were successfully amplified were shipped to Functional Biosciences, Madison, Wisconsin (<http://order.functionalbio.com/seq/index>), where they were sequenced through the use of ABI 3730XL DNA sequencer based on Sanger sequencing technology.

### Bioinformatics Analyses of DNA Sequence Results

After direct DNA sequencing, chromatograms generated were transferred to a Unix workstation, and the bases were called using PHRED (v. 0.961028) ([www.phrap.org/](http://www.phrap.org/)

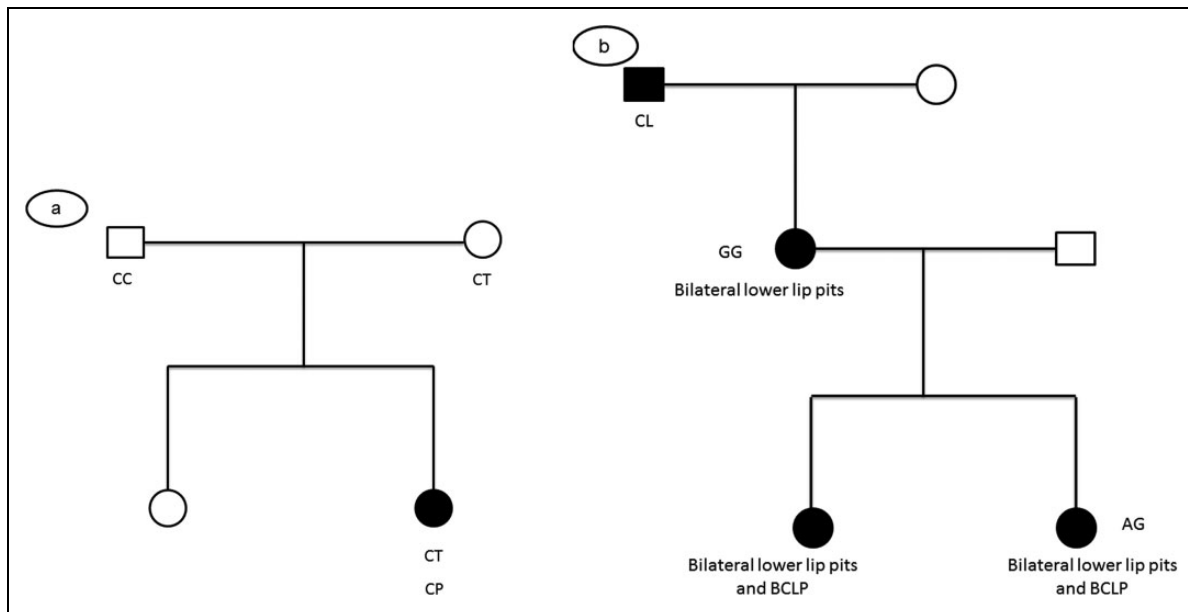

**Figure 1.** Pedigrees, phenotypes, and genotypes of individuals with potentially etiologic *GREM1* mutations. (A) Ghanaian case with p.Pro164Ser has cleft of the soft palate only (CP). (B) Ethiopian van der Woude syndrome case with p.Gly61Asp variant in *GREM1*. CL, cleft lip; BCLP, bilateral complete cleft lip and palate.

phredphrapconsd.html). Sequences were assembled to form the contigs employing PHRAP (v. 0.960731), scanned with POLYPHRED (v. 0.970312), and viewed employing CONSED (v. 4). We aligned our variants to human genome assembly number GRCh37/hg19, 2009 (<http://genome.ucsc.edu>) to ascertain the genomic loci or co-ordinates of variants. We designated variants as novel or known by comparing them to variants reported in 1000 Genomes (<http://www.1000genomes.org/>), Exome Aggregation Consortium (ExAC) (<http://exac.broadinstitute.org/>) and Exome Variant Server (EVS) (<http://snp.gs.washington.edu/EVS/>) databases as well as literature on CL/P. We further sequenced DNA from 192 Ghanaian and Ethiopian controls as an additional step to confirm the novelty and pathogenicity of identified mutations. As a segregation analyses, we sequenced DNA from relatives of individuals with the novel mutations to ascertain whether these variants were limited to cases or if they occurred in other relatives. We also predicted the functional effects of novel mutations on *GREM1* protein employing in silico bioinformatics tools such as PolyPhen 2 (<http://genetics.bwh.harvard.edu/pph2/>), SIFT (<http://sift.jcvi.org/>), and HOPE (<http://www.cmbi.ru.nl/hope>). All mutational analyses were based on ENSEMBL ([http://grch37.ensembl.org/Homo\\_sapiens/Tools/VEP/](http://grch37.ensembl.org/Homo_sapiens/Tools/VEP/)) canonical transcript number ENST00000300177.4.

## Results

We observed 2 potentially pathogenic missense variants in *GREM1*: c.490C>T (p.Pro164Ser) in a Ghanaian case with nonsyndromic incomplete CP (cleft of the soft palate only, Figure 1A) and c.182G>A (p.Gly61Asp) in an Ethiopian case with bilateral lip pits and bilateral CLP (ie, a case of Van

der Woude syndrome, OMIM 119300, <https://www.ncbi.nlm.nih.gov/omim>; Figure 1B). None of these variants have been reported in public genetic variant databases, suggesting that these mutations may be specific to the sub-Saharan African populations. We also did not observe these variants in 96 Ghanaian and 96 Ethiopian controls. PolyPhen 2 predicted that the p.Pro164Ser mutation is possibly damaging and this was confirmed by PROVEAN, which predicted that the mutation is deleterious with a score of  $-3.60$ ; however, SIFT predicted that the mutation is tolerated. For the p.Gly61Asp mutation, PolyPhen 2 predicted it is also possibly damaging; nonetheless, both SIFT and PROVEAN predicted it to be tolerated and neutral, respectively, with a PROVEAN score of 0.02.

Segregation analyses suggest that the *GREM1* variants identified here may not be completely penetrant. For the p.Pro164Ser mutation, the variant was observed in both the clinically unaffected mother and the proband with cleft of the soft palate only but the variant was not observed in the father (Figure 1A). We could not obtain samples from the father of the proband with p.Gly61Asp mutation (Figure 1B), to determine whether the variant was de novo or segregated in the family. Interestingly, the p.Gly61Asp mutation was observed in a VWS proband in which our group had earlier reported a nonsense mutation (p.Lys66X) in *IRF6* gene (Butali et al., 2014b).

Simulation or modeling of p.Pro164Ser mutant *GREM1* protein structure by HOPE also confirmed the probable pathogenicity of this variant (Figure 2). The wild-type proline residue is bigger and more hydrophobic than the mutant serine residue (Figure 2A). HOPE further predicts that the p.Gly61Asp mutation could also destabilize *GREM1* protein function for a number of biochemical reasons: the mutant aspartic acid residue is bigger, negatively charged, and less

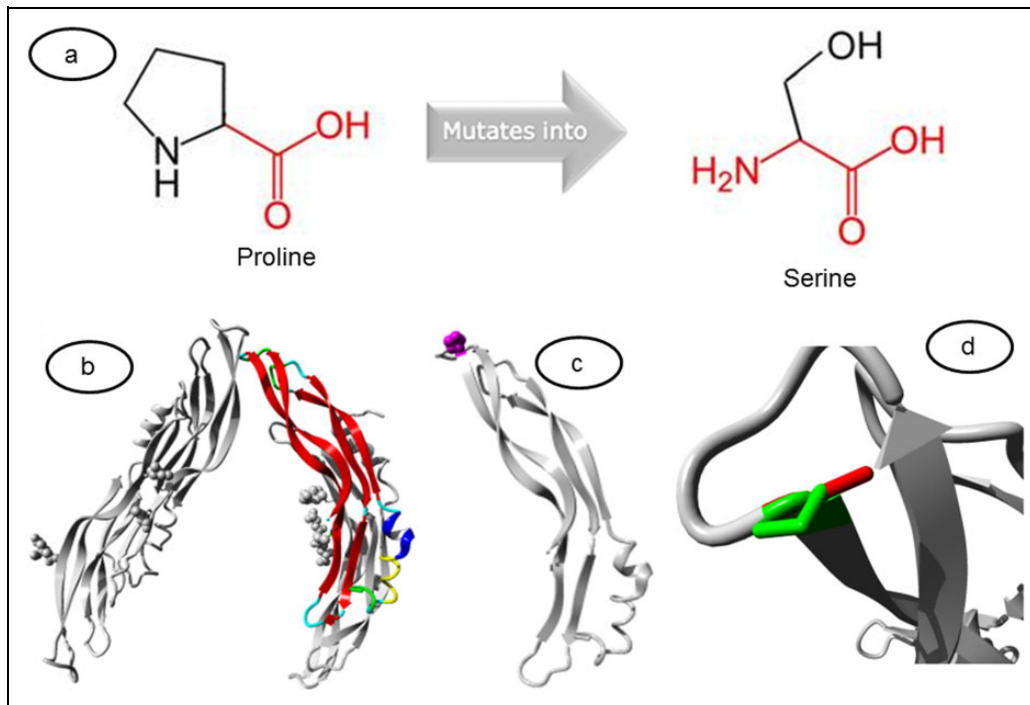

**Figure 2.** Simulation of mutant p.Pro164Ser mutant GREM1 protein structure by HOPE. (A) Substitution of proline for serine, which differ by size and hydrophobicity. (B) Ribbon-presentation of wild-type GREM1 protein demonstrating various residues (blue,  $\alpha$ -helix; red,  $\beta$ -helix; green, turn; yellow, 3/10 helix; cyan, random coil; gray, other complex molecules). (C) HOPE simulation shows that the p.Pro164Ser mutation (magenta and small balls) occurs in one of the random coils that is crucial for multimer contact. (D) A close-up view of the mutation showing the effects of the variations of side chains of wild-type and mutant amino acid residues on GREM1 protein (green, wild-type amino acid; red, mutant amino acid).

hydrophobic, whereas the wild-type glycine residue is smaller, neutral, and more hydrophobic.

## Discussion

We directly sequenced the *GREM1* gene exonic region on almost 400 cases with CL/P and observed only 2 potentially pathogenic exonic genetic mutations in 2 patients, one with nonsyndromic incomplete CP and the other presented with syndromic bilateral CLP. Our observations suggest that rare variants in *GREM1* could increase the risk of nonsyndromic CP (p.Pro164Ser) or contribute to the cleft phenotype in VWS patients (p.Gly61Asp) among sub-Saharan Africans. We did not observe any of these 2 variants in any of the almost 200 population-specific controls we sequenced. Inasmuch as the almost 200 population-specific controls may have reduced power to detect these 2 variants, the observation that these variants have never been reported in 1000 Genomes, EVS, and ExAC, which include more than 5000 Africans and African Americans, may give credence to the probable pathogenicity of these 2 variants. A GWAS (Mangold et al., 2010) as well as a study that combined both replication study and GWAS data (Ludwig et al., 2016) has demonstrated earlier that *GREM1* may play a crucial role in the etiology of nonsyndromic CL/P, especially a subphenotype of nonsyndromic CLP that involves cleft of both the lip and soft palate only but excluding the hard palate. In a replication study we conducted earlier

(Gowans et al., 2016), the *GREM1* locus did not attain statistical significance perhaps because of the small nonsyndromic CLP sample size and disregard for CLP subphenotype analysis.

We have also demonstrated that *GREM1* gene has a low number of etiologic exonic variants in CL/P patients. This confirmed observations made by an earlier study (Al Chawa et al., 2014) that could not detect any pathogenic mutations in this gene. Our observations and those made by another study (Mostowska et al., 2015) suggest that variants in regulatory elements, such as enhancers, that may affect the level of expression of this gene may largely be responsible for the association between this gene and CL/P. This argument is further corroborated by the observation that duplication of DNA sequences upstream of *GREM1* affects the level of expression of *GREM1* and this is what has been associated with HMPS1 (Jaeger et al., 2012), instead of pathogenic exonic variants.

HOPE predicted that the 2 novel variants we observed in *GREM1* are probably pathogenic for a number of biochemical reasons. According to HOPE, the mutated residue of p.Pro164-Ser occurs within the Cystine Knot, C-terminal (CTCK) domain of GREM1 protein and the substitution of proline for serine in this domain may abolish CTCK domain function. Moreover, the replacement of glycine by aspartic acid in the p.Gly61Asp variant results in the introduction of negative charge by the mutant residue and this may lead to repulsion of ligands or other residues with the same charge. Finally, HOPE predicts that the torsion angles of the residue at position

61 of GREM1 protein are unusual, and only glycine is flexible enough to make such torsion angles.

Our segregation analysis suggested that the p.Pro164Ser variant may not be completely penetrant as this variant occurred in both clinically unaffected mother and a proband with incomplete CP that involves cleft of the soft palate only. However, we cannot rule out the fact that the mother could have subclinical CL/P phenotype, because this study was not designed to ascertain subclinical phenotypes. The soft palate only cleft observation suggests that *GREM1* mutations may not always manifest as the nonsyndromic CLP subphenotype reported by Ludwig et al. (2016) that demonstrated through mouse embryogenesis that *GREM1* is expressed in both the developing lip and soft palate but not the hard palate. Moreover, this CP observation buttresses the observation made by Erdogan et al. (2007) that demonstrated that variants in *GREM1* may cause CP. It is difficult to predict the contribution of the *GREM1* mutation to the bilateral CLP phenotype in the patient with p.Gly61Asp variant; however, it is possible that the *GREM1* mutation contributed to the cleft lip and soft palate cleft subphenotype, because variants in this gene have been shown to be highly associated with this nonsyndromic CLP subphenotype (Ludwig et al., 2016). Because we had DNA samples for only the proband and the mother as far as this family is concerned, we were unable to determine the *IRF6* and *GREM1* genotypes for each individual in this family. This would have helped us to explain the probable role of *GREM1* as a modifier of *IRF6* phenotype. Functional studies may be needed to validate the pathogenicity of the novel and private sub-Saharan variants we have reported in this study. This is warranted by the inconsistencies in effects of these variants on GREM1 protein structure due to different predicted pathogenicity from SIFT, PROVEAN, PolyPhen-2, and HOPE.

## Conclusion

Through DNA resequencing studies of almost 400 CL/P patients, we have shown for the first time among CL/P patients evidence of 2 potentially etiologic or contributory coding variants in *GREM1* gene. However, the low number of pathogenic mutations in *GREM1* coding sequence suggests that coding variants in this gene may not significantly contribute to the genetic etiology of CL/P in sub-Saharan Africans. Moreover, the low number of etiologic coding variants also confirms earlier suggestions that variants in regulatory elements may largely account for the association between the *GREM1* locus and CL/P. In vivo functional studies are required to identify these elements.

## Acknowledgment

We greatly appreciate the families that participated in this study as well as doctors and nurses at the various teaching hospitals where sample collection was carried out.

## Declaration of Conflicting Interests

The authors declared no potential conflicts of interest with respect to the research, authorship, and/or publication of this article.

## Funding

The author(s) disclosed receipt of the following financial support for the research, authorship, and/or publication of this article: This work was supported by National Institute of Dental and Craniofacial Research (R00 DE022378) and the Robert Wood Johnson Foundation (72429; A.B.); the National Institutes of Health (R37 DE-08559, J.C.M.; and DE-016148, M.L.M.) and the Ghana Cleft Foundation (L.J.J.G.).

## ORCID iD

Arwa Owais  <http://orcid.org/0000-0002-3391-2976>

## References

- Al Chawa T, Ludwig KU, Fier H, Pöttsch B, Reich RH, Schmidt G, Braumann B, Daratsianos N, Böhmer AC, Schuencke H, et al. Nonsyndromic cleft lip with or without cleft palate: increased burden of rare variants within Gremlin-1, a component of the bone morphogenetic protein 4 pathway. *Birth Defects Res A Clin Mol Teratol*. 2014;100:493-498.
- Beaty TH, Marazita ML, Leslie EJ. Genetic factors influencing risk to orofacial clefts: today's challenges and tomorrow's opportunities. *F1000Res*. 2016;5:2800. eCollection 2016.
- Boehringer S, van der Lijn F, Liu F, Günther M, Sinigerova S, Nowak S, Ludwig KU, Herberz R, Klein S, Hofman A, et al. Genetic determination of human facial morphology: links between cleft-lips and normal variation. *Eur J Hum Genet*. 2011;19:1192-1197.
- Butali A, Mossey P, Adeyemo W, Eshete M, Gaines L, Braimah R, Aregbesola B, Rigdon J, Emeka C, Olutayo J, et al. Rare functional variants in genome-wide association identified candidate genes for nonsyndromic clefts in the African population. *Am J Med Genet A*. 2014a;164A:2567-2571.
- Butali A, Mossey PA, Adeyemo WL, Eshete MA, Gaines LA, Even D, Braimah RO, Aregbesola BS, Rigdon JV, Emeka CI, et al. Novel *IRF6* mutations in families with Van Der Woude syndrome and popliteal pterygium syndrome from sub-Saharan Africa. *Mol Genet Genomic Med*. 2014b;2:254-260.
- Butali A, Mossey PA, Adeyemo WL, Jezewski PA, Onwuamah CK, Ogunlewe MO, Ugboko VI, Adejuyigbe O, Adigun AI, Abdur-Rahman LO, et al.; NigeriaCRAN Collaboration. Genetic studies in the Nigerian population implicate an *MSX1* mutation in complex oral facial clefting disorders. *Cleft Palate Craniofac J*. 2011; 48:646-653.
- Dixon MJ, Marazita ML, Beaty TH, Murray JC. Cleft lip and palate: understanding genetic and environmental influences. *Nat Rev Genet*. 2011;12:167-178.
- Erdogan F, Ullmann R, Chen W, Schubert M, Adolph S, Hultschig C, Kalscheuer V, Ropers HH, Spaich C, Tzschach A. Characterization of a 5.3 Mb deletion in 15q14 by comparative genomic hybridization using a whole genome "tiling path" BAC array in a girl with heart defect, cleft palate, and developmental delay. *Am J Med Genet A*. 2007;143A:172-178.

- Gowans LJ, Adeyemo WL, Eshete M, Mossey PA, Busch T, Aregbetsola B, Donkor P, Arthur FK, Bello SA, Martinez A, et al. Association studies and direct DNA sequencing implicate genetic susceptibility loci in the etiology of nonsyndromic orofacial clefts in sub-Saharan African populations. *J Dent Res.* 2016;95:1245-1256.
- Jaeger E, Leedham S, Lewis A, Segditsas S, Becker M, Cuadrado PR, Davis H, Kaur K, Heinemann K, Howarth K, et al. Hereditary mixed polyposis syndrome is caused by a 40-kb upstream duplication that leads to increased and ectopic expression of the BMP antagonist GREM1. *Nat Genet.* 2012;44:699-6703.
- Leslie EJ, Carlson JC, Shaffer JR, Butali A, Buxó CJ, Castilla EE, Christensen K, Deleyiannis FW, Leigh Field L, Hecht JT, et al. Genome-wide meta-analyses of nonsyndromic orofacial clefts identify novel associations between *FOXE1* and all orofacial clefts, and *TP63* and cleft lip with or without cleft palate. *Hum Genet.* 2017;13:275-286.
- Leslie EJ, Carlson JC, Shaffer JR, Feingold E, Wehby G, Laurie CA, Jain D, Laurie CC, Doheny KF, McHenry T, et al. A multi-ethnic genome-wide association study identifies novel loci for nonsyndromic cleft lip with or without cleft palate on 2p24.2, 17q23 and 19q13. *Hum Mol Genet.* 2016;25:2862-2872.
- Leslie EJ, Liu H, Carlson JC, Shaffer JR, Feingold E, Wehby G, Laurie CA, Jain D, Laurie CC, Doheny KF, et al. A genome-wide association study of nonsyndromic cleft palate identifies an etiologic missense variant in *GRHL3*. *Am J Hum Genet.* 2016;98:744-754.
- Ludwig KU, Ahmed ST, Böhmer AC, Sangani NB, Varghese S, Klamt J, Schuenke H, Gültepe P, Hofmann A, Rubini M, et al. Meta-analysis reveals genome-wide significance at 15q13 for nonsyndromic clefting of both the lip and the palate, and functional analyses implicate *GREM1* as a plausible causative gene. *PLoS Genet.* 2016;12:e1005914.
- Ludwig KU, Böhmer AC, Bowes J, Nikolić M, Ishorst N, Wyatt N, Hammond NL, Gözl L, Thieme F, Barth S, et al. Imputation of orofacial clefting data identifies novel risk loci and sheds light on the genetic background of cleft lip  $\pm$  cleft palate and cleft palate only. *Hum Mol Genet.* 2017;26:829-842.
- Mangold E, Ludwig KU, Birnbaum S, Baluardo C, Ferrian M, Herms S, Reutter H, de Assis NA, Chawa TA, Mattheisen M, et al. Genome-wide association study identifies two susceptibility loci for nonsyndromic cleft lip with or without cleft palate. *Nat Genet.* 2010;42:24-26.
- Mossey PA, Modell B. Epidemiology of oral clefts 2012: an international perspective. *Front Oral Biol.* 2012;16:1-18.
- Mostowska A, Hozyasz KK, Wójcicki P, Żukowski K, Dąbrowska A, Lasota A, Zadurska M, Radomska A, Dunin-Wilczyńska I, Jagodziński PP. Association between polymorphisms at the *GREM1* locus and the risk of nonsyndromic cleft lip with or without cleft palate in the Polish population. *Birth Defects Res A Clin Mol Teratol.* 2015;103:847-856.
- Suzuki S, Marazita ML, Cooper ME, Miwa N, Hing A, Jugessur A, Natsume N, Shimozato K, Ohbayashi N, Suzuki Y, et al. Mutations in *BMP4* are associated with subepithelial, microform, and overt cleft lip. *Am J Hum Genet.* 2009;84:406-411.
- Topol LZ, Modi WS, Koochekpour S, Blair DG. DRM/GREMLIN (*CKTSF1B1*) maps to human chromosome 15 and is highly expressed in adult and fetal brain. *Cytogenet Cell Genet.* 2000;89:79-84.
- Yu Y, Zuo X, He M, Gao J, Fu Y, Qin C, Meng L, Wang W, Song Y, Cheng Y, et al. Genome-wide analyses of non-syndromic cleft lip with palate identify 14 novel loci and genetic heterogeneity. *Nat Commun.* 2017;8:14364.